

Change Your Energy Charge Your Life



Compact Size & Easy Installation

The compact and lightweight nature of the RESU is world-class. It is designed to allow easy wall-mounted or floor-standing installation for both indoor and outdoor applications. The inverter connections have also been simplified, reducing installation time and costs.



Powerful Performance

The new RESU series features industry-leading continuous power (4.2kW for RESU6.5) and DC round-trip efficiency (95%). LG Chem's L&S (Lamination & Stacking) technology provides durability ensuring 80% of capacity retention after 10 years.



Proven Safety

LG Chem places the highest priority on safety and utilizes the same technology for its ESS products that has a proven safety record in its automotive battery. All products are fully certified in relevant global standards.





Energy Independence for your Residential Solar System



Add a 10 Kw Battery to
your solar system for as

little as

\$63/month

 **LG Chem**

RESU10H

9.8 kWh Lithium Ion Battery Pack Product

MODEL	RESU10H
TOTAL ENERGY (kWh)	9.8 kWh @25°C (77°F)
USABLE ENERGY (kWh)	9.3 kWh @25°C (77°F)
CAPACITY	63
VOLTAGE RANGE (V)	CHARGE 400 – 450 VDC DISCHARGE 350 – 430 VDC
ABSOLUTE MAX. VOLTAGE	520 VDC
INSTALLATION LOCATION	INDOOR (WALL-MOUNTED) / OUTDOOR
CONNECTION METHOD	SPRING TYPE CONNECTOR
PROTECTION FEATURES	OVER VOLTAGE/ OVER CURRENT/ SHORT CIRCUIT/ REVERSE POLARITY
COMMUNICATION INTERFACE	RS485
DC DISCONNECT	CIRCUIT BREAKER, 25A, 600V RATING
CERTIFICATION (BATTERY PACK)	CE / TUV (IEC 62619) / UL1973
EMISSIONS	FCC

NOTE:

RESU10H must be installed with an existing solar energy system. It cannot be purchased as a standalone battery.

Mechanical Characteristics

DIMENSIONS	WIDTH	744 mm (29.3")
	HEIGHT	907 mm (35.7")
	DEPTH	206 mm (8.1")
WEIGHT		97 kg (214 lbs.)

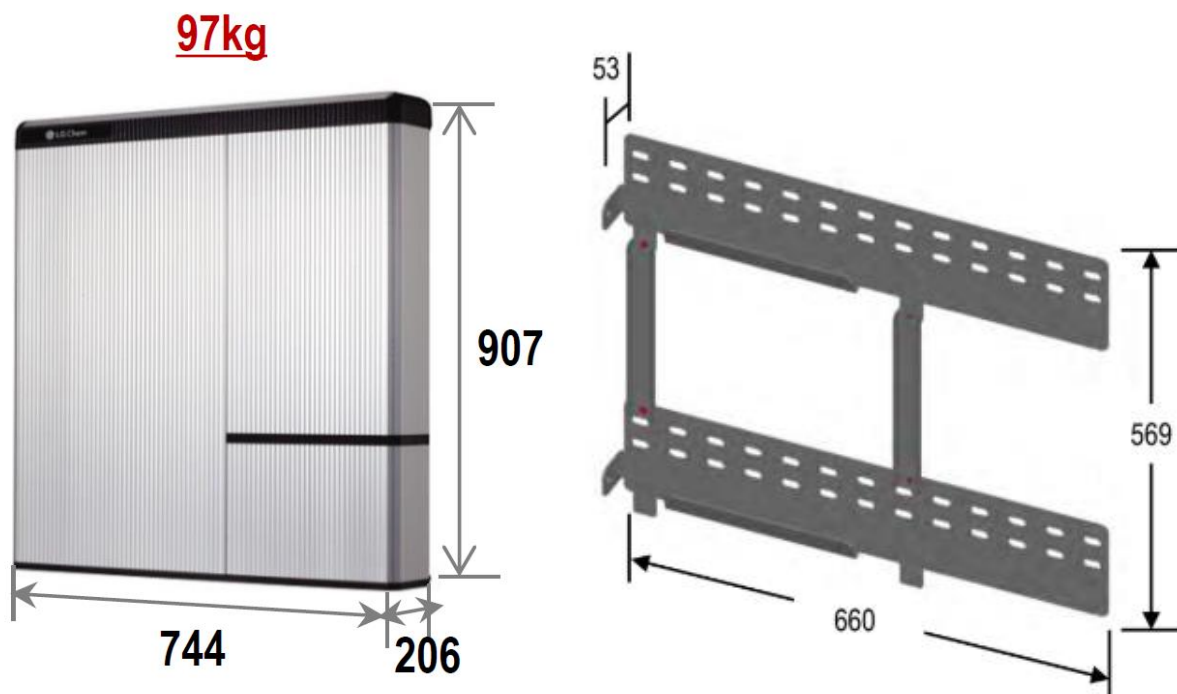

SOLAR SMART LIVING can add an LG Chem battery to your solar system and warranty it for 10 years. You may also add up to one additional battery for a total of 20kW of backup power.



<http://www.lgesspartner.com/>
<http://www.lgchem.com/>

Solution *PARTNER*

108 Ray Ward Place
 Santa Teresa, NM 88008
 Tel: (915) 400-2995

<http://solarsmartliving.com/>

